

TRIXIE

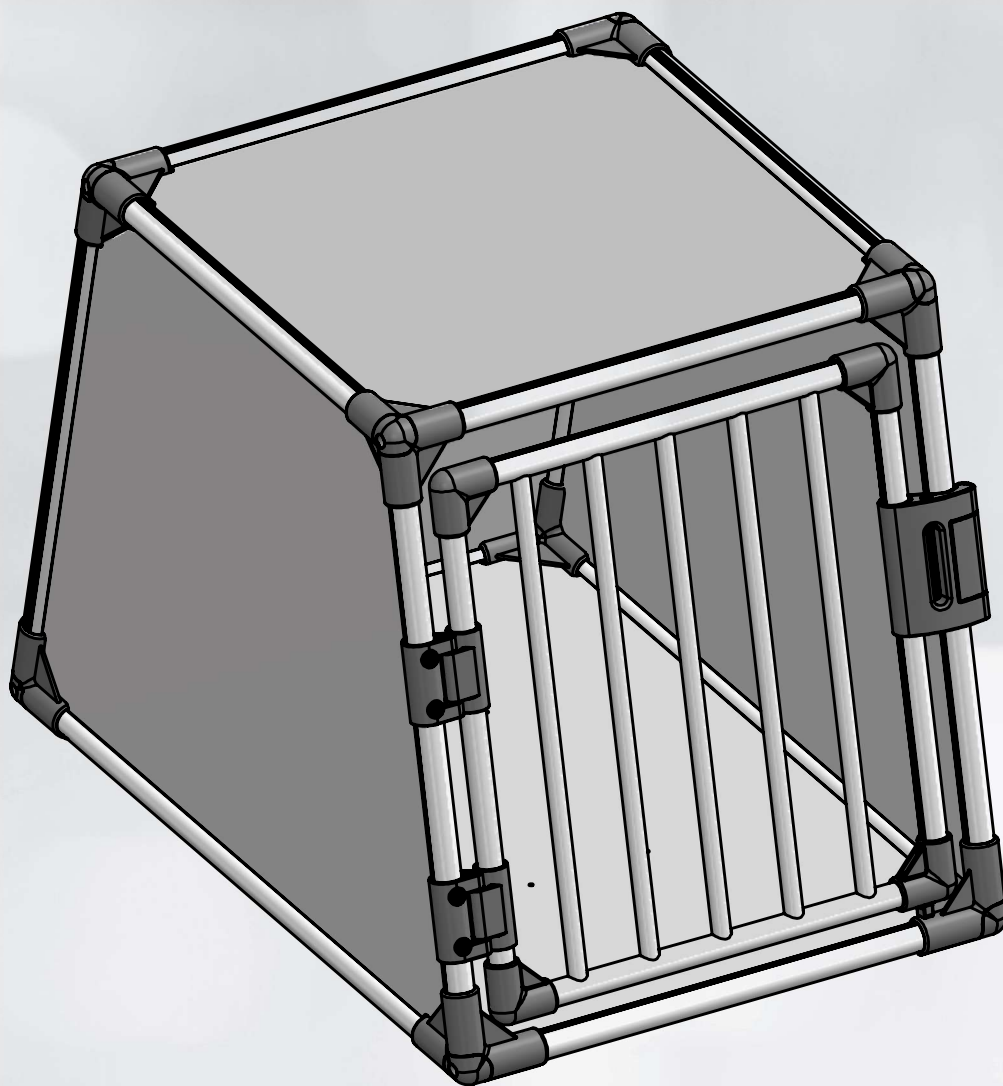

Anleitung #39335/39336/39337

(EN) Instructions

(FR) Instructions

(IT) Istruzioni

(NL) Instructies

(SV) Instruktioner

(DA) Vejledning



(ES) Instrucciones





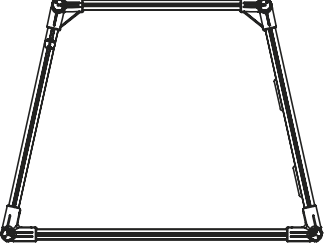
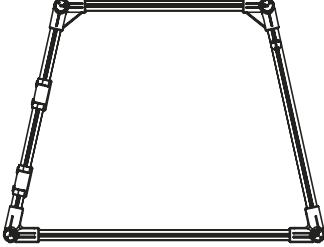
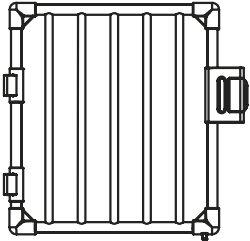
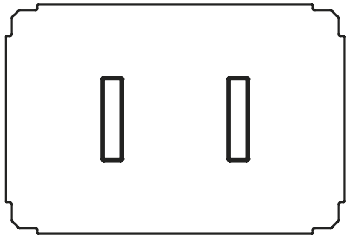
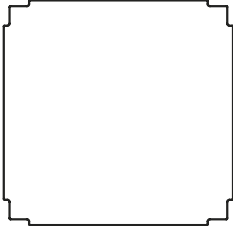

(PT) Instruções

(PL) Instrukcja

(CS) Instrukce

(RU) Инструкция

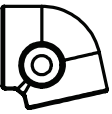
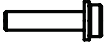
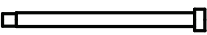
<p>1</p>	<p>Seitenwand, rechts / Side panel, right / Panneau latéral, droit / Pannello laterale, destro / Zijwand, rechts / Sidopanel, höger / Sidepanel, højre / Panel lateral derecho / Painel lateral, direita / Panel boczny, prawy / Boční panel, pravý / Правая боковая панель</p>		<p>1x</p>	<p>39335-13/ 39336-13/ 39337-13</p>
<p>2</p>	<p>Seitenwand, links / Side panel, left / Panneau latéral, gauche / Pannello laterale, sinistro / Zijwand, links / Sidopanel, vänster / Sidepanel, venstre / Panel lateral, izquierdo / Painel lateral, esquerda / Panel boczny, lewy / Boční panel, levý / Левая боковая панель</p>		<p>1x</p>	<p>39335-12/ 39336-12/ 39337-12</p>
<p>3</p>	<p>Tür / Door / Porte / Porta / Deur / Dörr / Dør / Puerta / Porta / Drzwi / Dvířka / Дверца</p>		<p>1x</p>	<p>39335-15/ 39336-15/ 39337-15</p>
<p>4</p>	<p>Boden / Base / Base / Base / Bodem / Botten / Bund / Base / Base / Podstawa / Základna / Нижняя панель</p>		<p>1x</p>	<p>39335-10/ 39336-10/ 39337-10</p>
<p>5</p>	<p>Dach / Top / Toit / Pannello superiore / Dak / Tak / Top / Parte superior / Tопо / Dach / Strop / Верхняя панель</p>		<p>1x</p>	<p>39335-14/ 39336-14/ 39337-14</p>
<p>6</p>	<p>Rückwand / Back panel / Panneau arrière / Pannello posteriore / Achterwand / Bakre panel / Bagpanel / Panel posterior / Painel traseiro / Panel tylny / Zadní panel / Задняя панель</p>		<p>1x</p>	<p>39335-11/ 39336-11/ 39337-11</p>
<p>7</p>	<p>Einlegematte / Fitted mat / Tapis de sol / Materassino / Inlegmat / Inläggssdyna / Tilpasset måtte / Alfombrilla a medida / Tapete / Mata / Podložka / Коврик</p>		<p>1x</p>	<p>39335-01/ 39336-01/ 39337-01</p>

8	Stange, Rückwand-Profilstrebe / Rod, back panel profiled rod / Tige, tige profilée du panneau arrière / Barra perfilada per il pannello posteriore / Stang, profilsteun achterwand / Stång, profilstång för bakpanelen / Stang, bagpanel profileret stang / Varilla, varilla perfilada del panel posterior / Haste, haste perfilada painel traseiro / Pręt, profilowany pręt tylnego panelu / Profilovaná tyč k zadnímu panelu / Профилированный стержень для задней панели		1x	39335-17/ 39336-17/ 39337-17
9	Stange, oben vorne/hinten / Rod, top front/back / Tige, haut avant/arrière / Barra, superiore anteriore/posteriore / Stang, boven voor/achter / Stång, övre fram/bak / Stang, top front/bag / Varilla, parte superior delantera/trasera / Haste, topo frente/traseira / Pręt, góra przód/tył / Tyč, horní předo/zadní / Стержень для верхней задней/передней панели		2x	39335-18/ 39336-18/ 39337-18
10	Stange, unten hinten / Rod, bottom back / Tige, en bas arrière / Barra, base posteriore / Stang, onder achter / Stång, nedre bak / Stang, bund bag / Varilla, parte inferior trasera / Haste, fundo traseira / Pręt, dół tył / Tyč spodní zadní / Стержень для нижней задней панели		1x	39335-19/ 39336-19/ 39337-19
11	Stange, unten vorne / Rod, bottom front / Tige, en bas avant / Barra, base anteriore / Stang, onder voor / Stång, nedre fram / Stang, bund front / Varilla, parte inferior delantera / Haste, fundo frente / Pręt, dół przód / Tyč spodní přední / Стержень для нижней передней панели Krallenschutz / Claw protection / Protection des griffes / Protezione antigraffio / Nagelbeschermering / Kloskydd / Beskyttelse til kløer / Protección de garras / Proteção das garras / Osłona pazurów / Ochrana drápků / Защита от когтей		1x	39335-19/ 39336-19/ 39337-19 + 39340-25
A	Schutzkappe, oben / Protective cap, top / Capuchon de protection, haut / Cappuccio di protezione, superiore / Beschermakap, boven / Skyddskåpa, topp / Beskyttelseskappe, top / Tapa protectora, parte superior / Tampa de proteção, topo / Osłona, góra / Ochranný klobouček, horní / Защитный калпачок, верхний		4x	
B	Schutzkappe, unten / Protective cap, bottom / Capuchon de protection, fond / Cappuccio di protezione, inferiore / Beschermakap, onder / Skyddskåpa, botten / Beskyttendekappe, bund / Tapa protectora, parte inferior / Tampa de proteção, fundo / Osłona, dół / Ochranný klobouček, spodní / Защитный калпачок, нижний		4x	3933-65
C	Schraube / Screw / Vis / Vite / Schroef / Skruv / Skrue / Tornillo / Parafuso / Śruba / Šroubek / Винт		8x	
D	Metallstift für Tür / Metal pin for door / Goupille métallique pour porte / Punta in metallo per la porta / Metalen pin voor deur / Metallstift för dörr / Metalpind til dør / Pasador de metal para puerta / Pino metálico para porta / Metalowy trzpień do drzwi / Kovová západka ke dvířkům / Металлический винт для дверцы		2x	
E	Mutter für Metallstift / Nut for metal pin / Ecrou pour goupille métallique / Dado per punta in metallo / Moer voor metalen pin / Mutter för metallstift / Møtrik til dør / Tuerca para el pasador de metal / Porca para pino metálico / Nakrętka do metalowego trzpienia / Matice pro západku / Гайка для металлического штифта		2x	3934-63

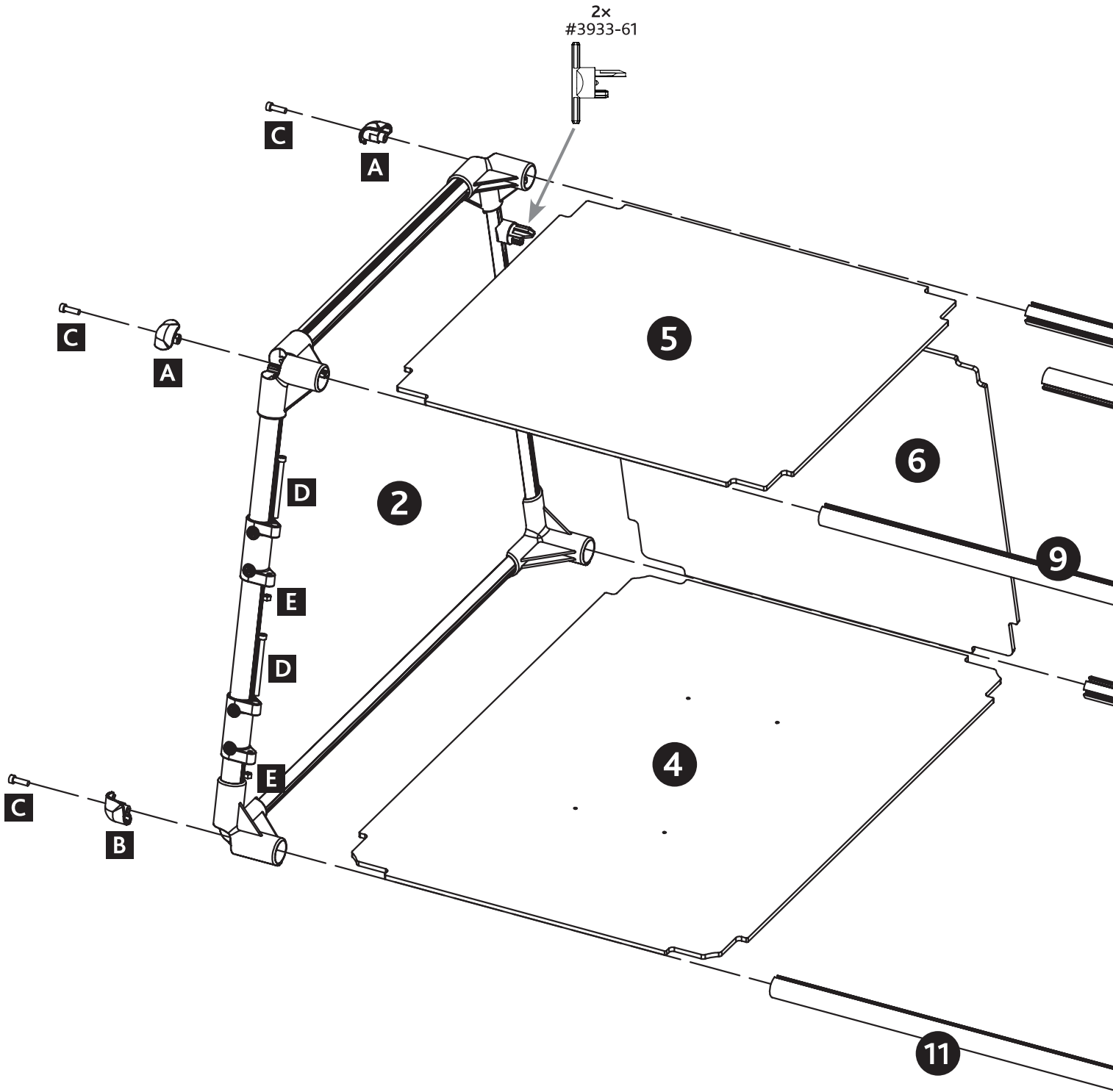

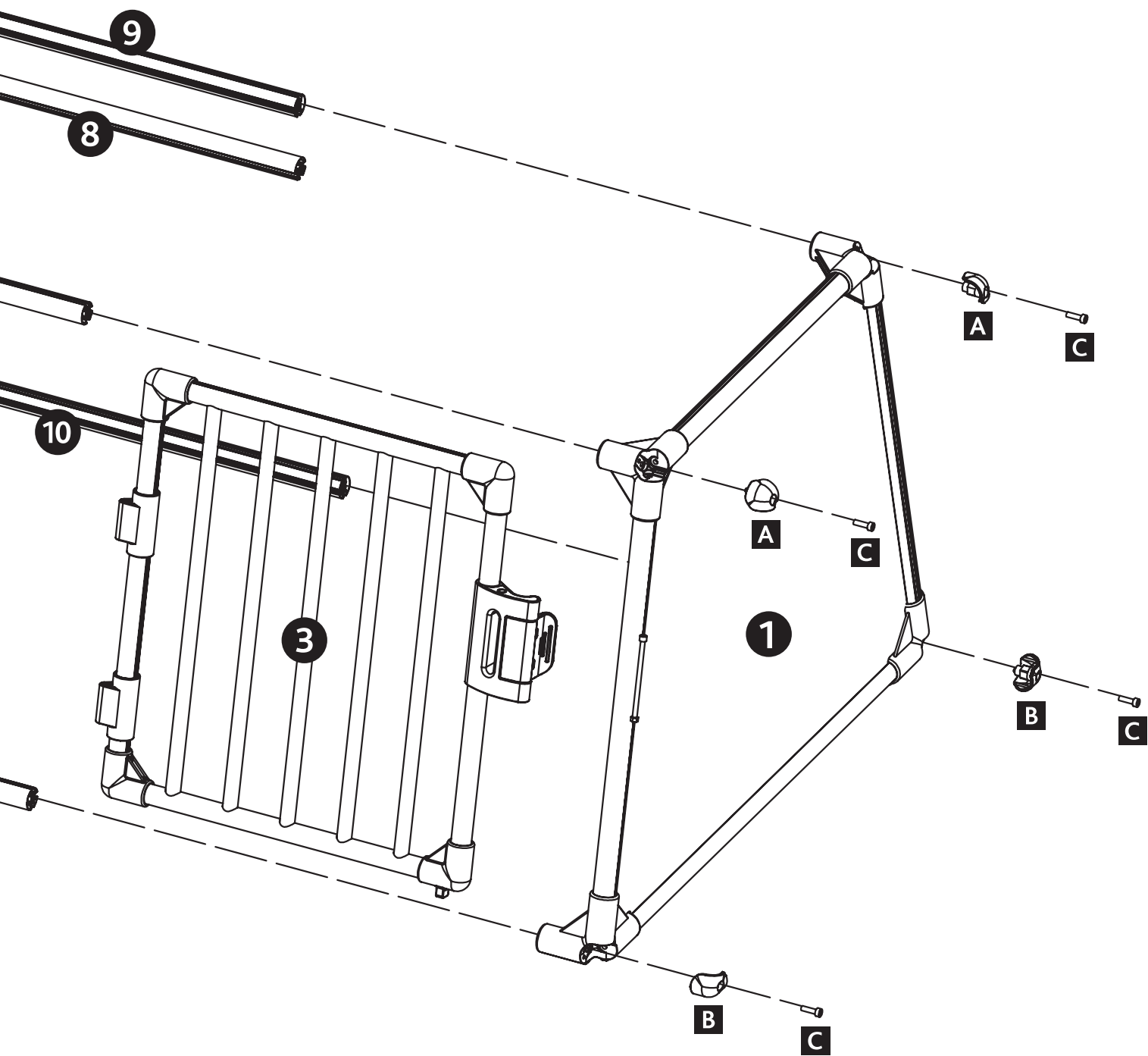

1.

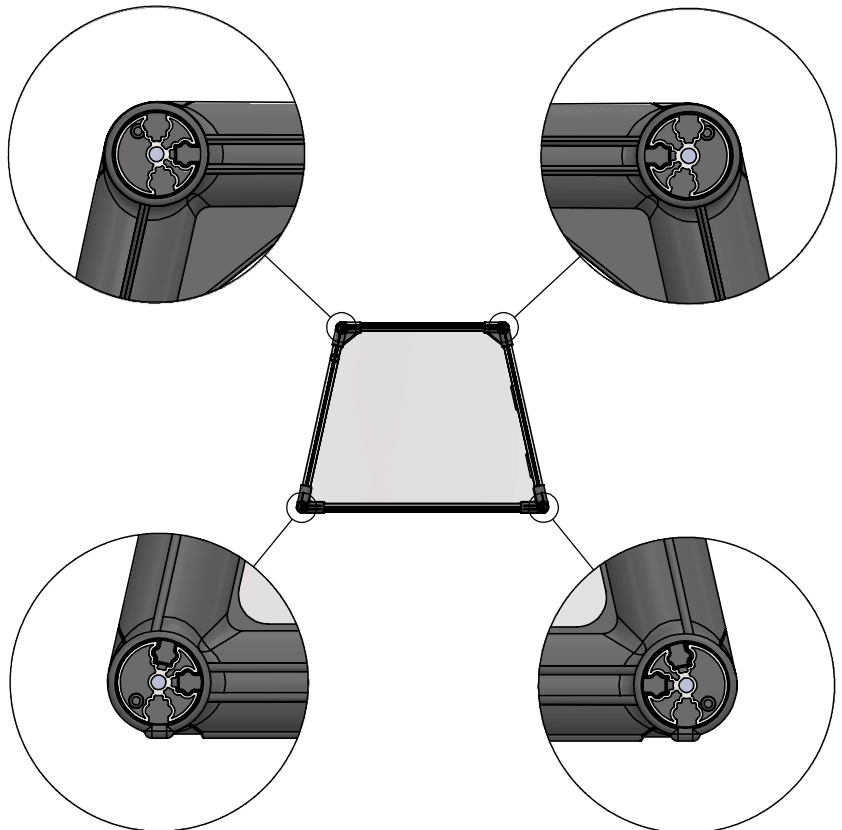
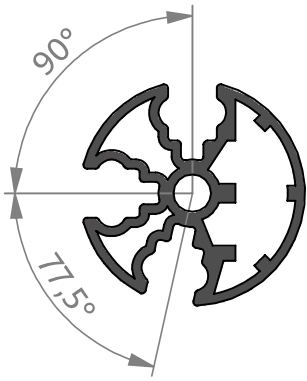
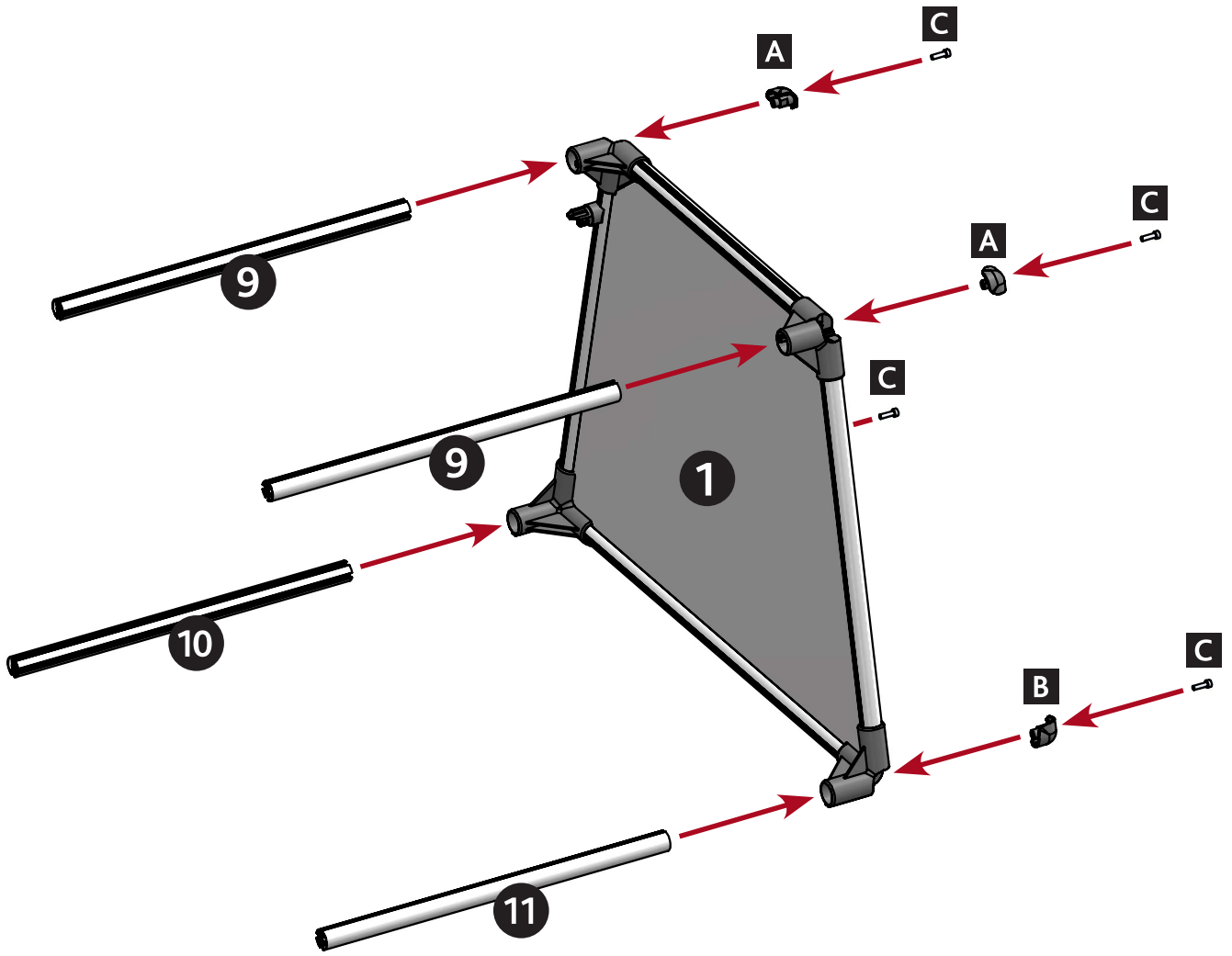

2.

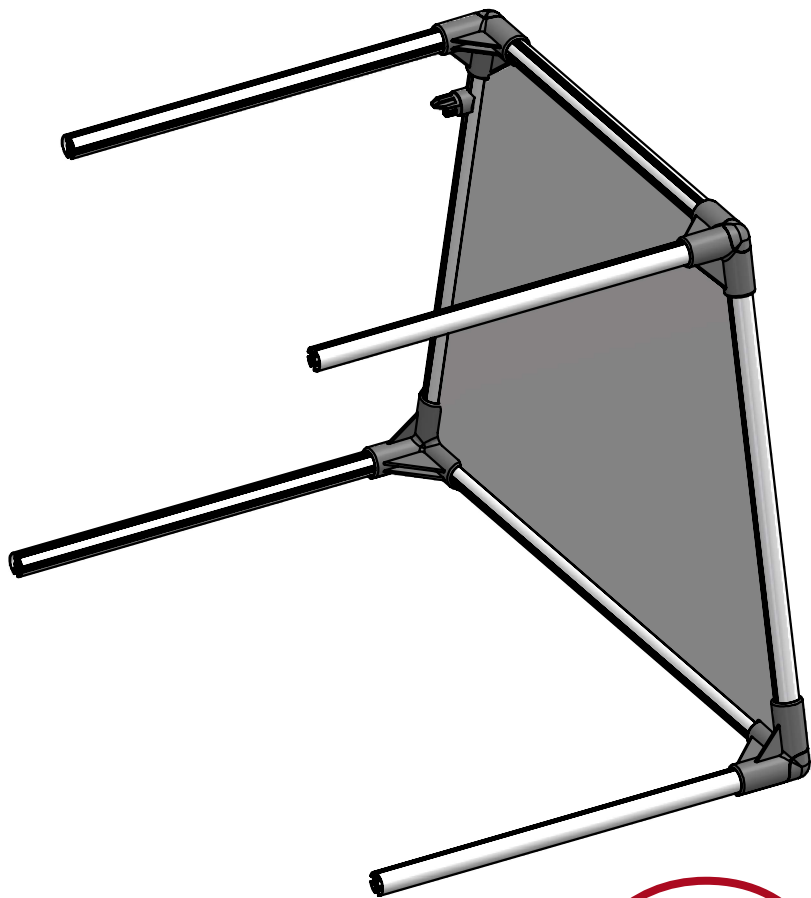

3.

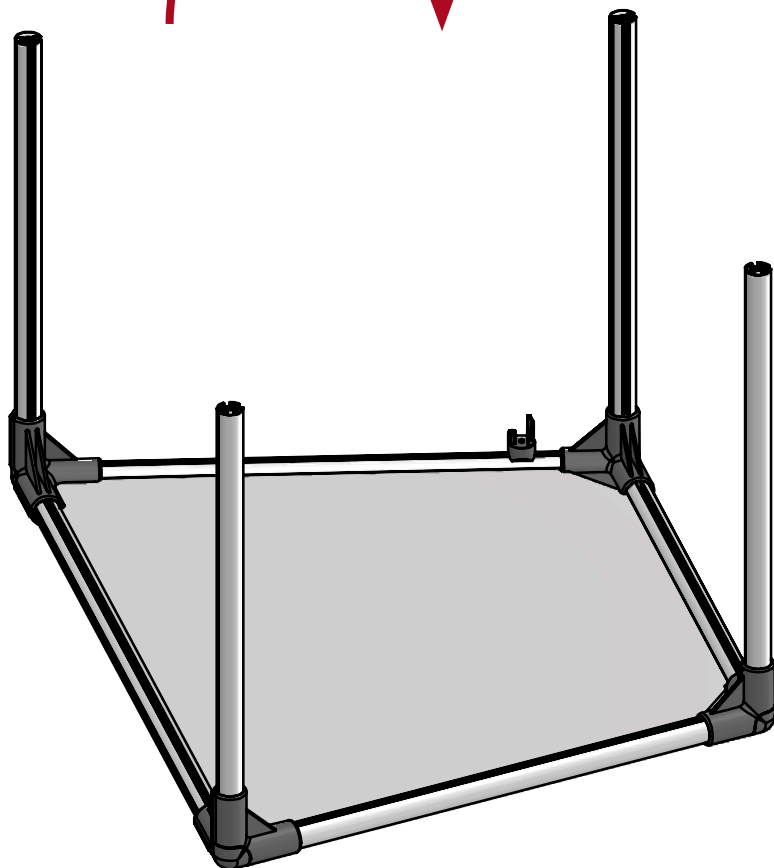

4.

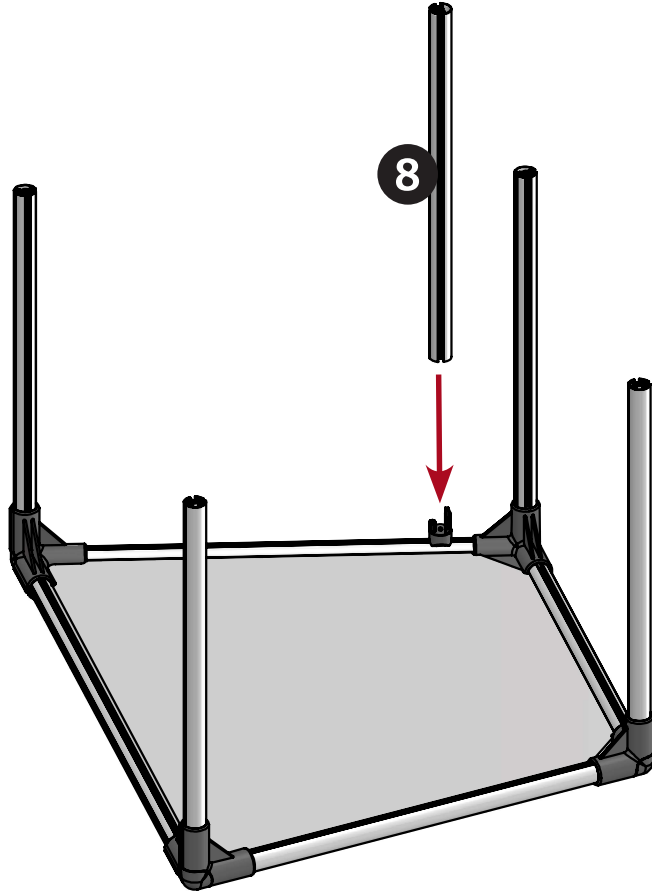

5.

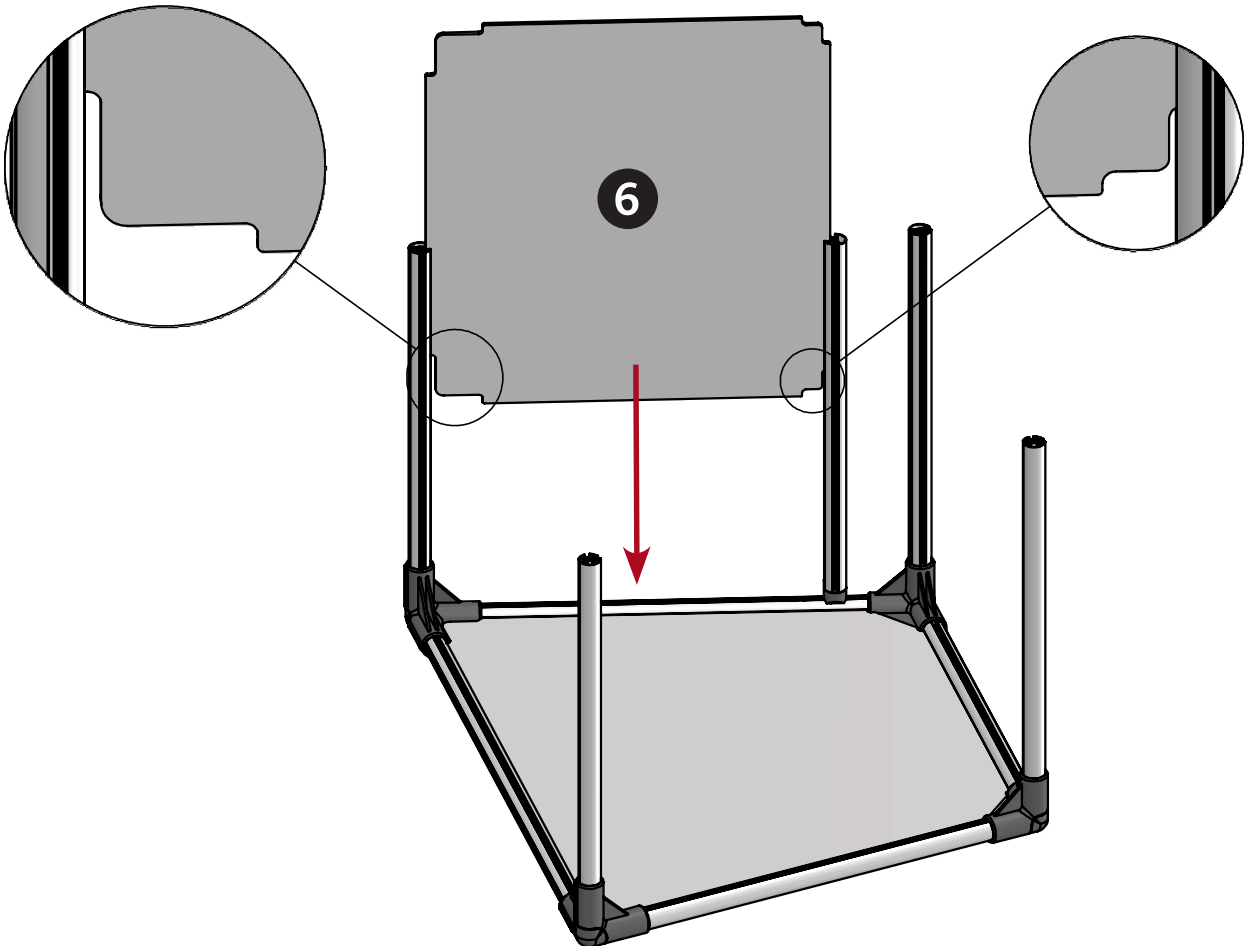

6.

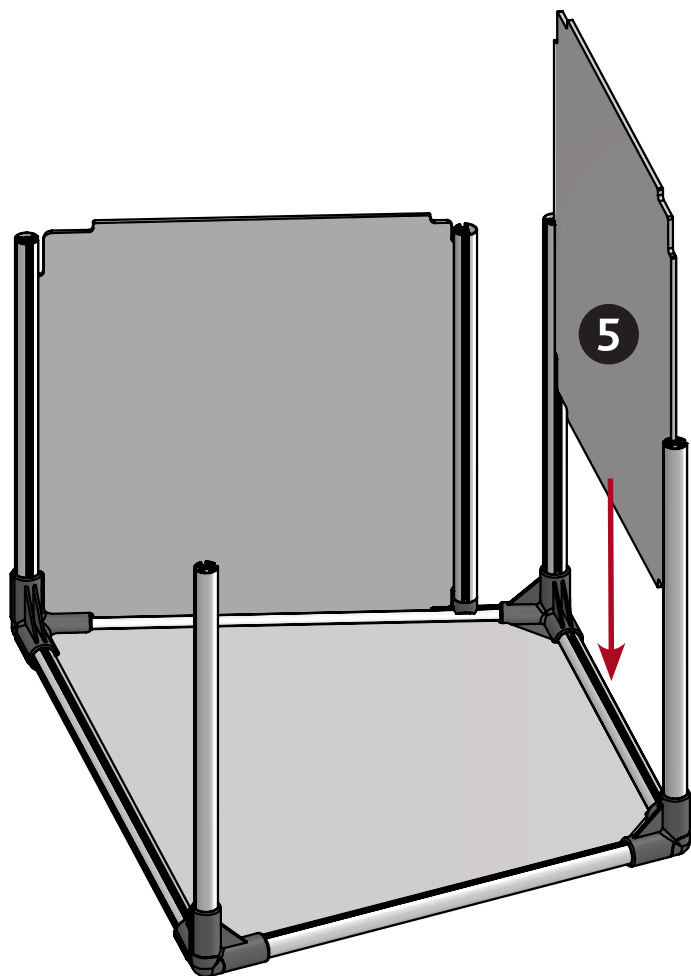

7.

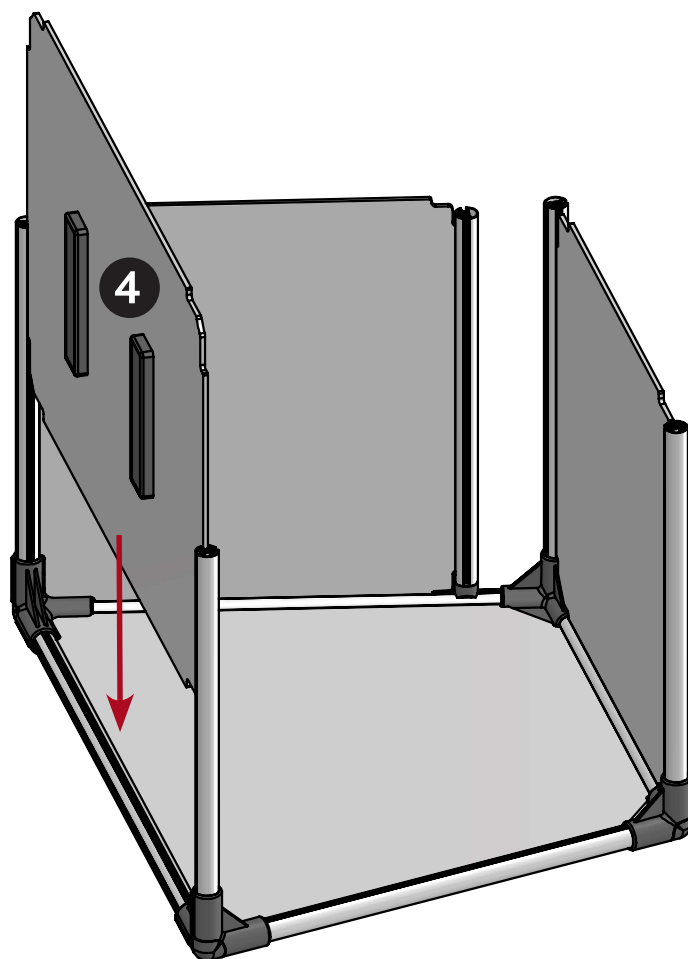

8.

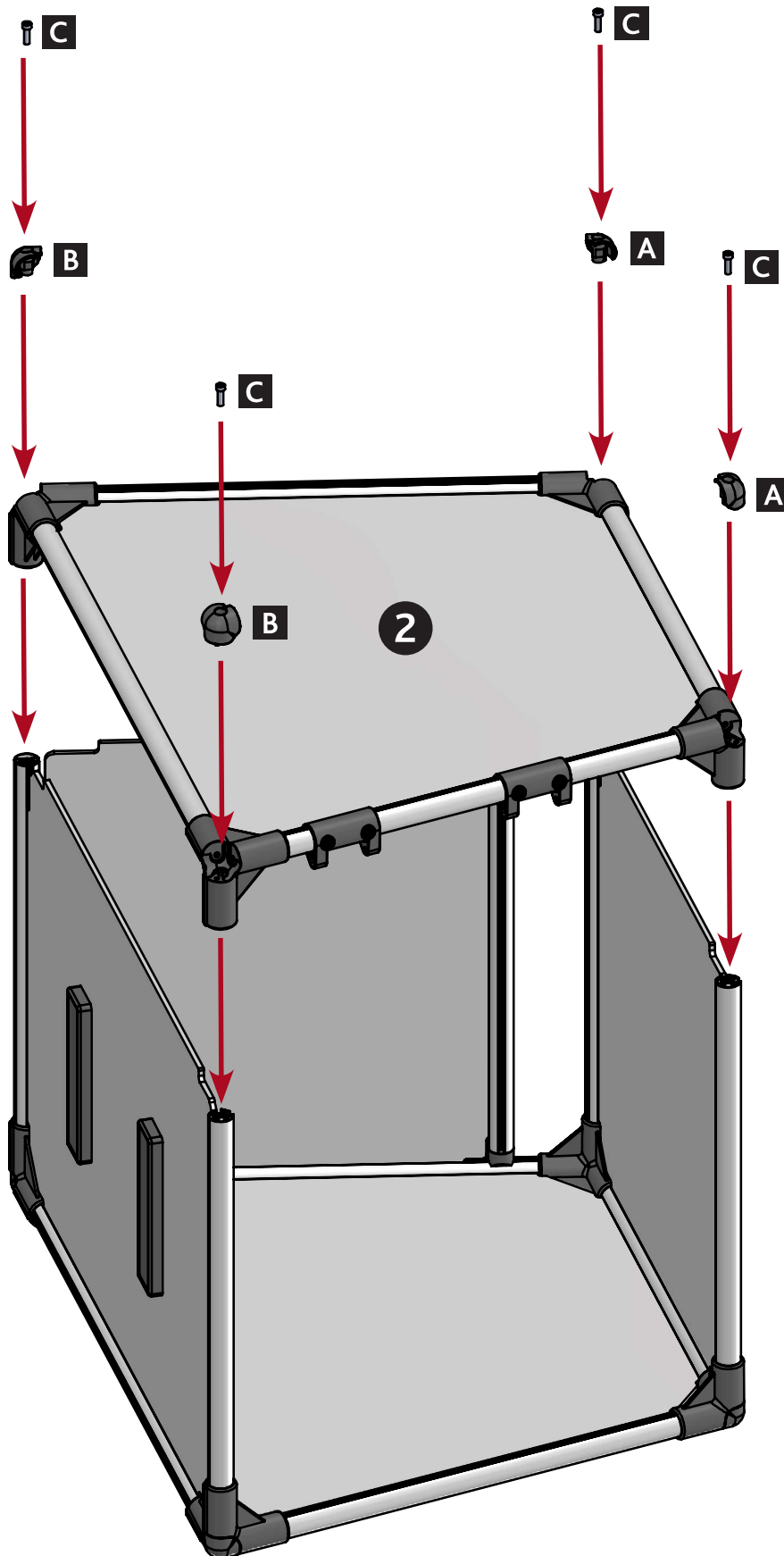

Ⓢ Sollte sich die Seitenwand nicht aufsetzen lassen, lockern Sie die an den Ecken vormontierten Schrauben dieses Elements. / Ⓣ If the side panel cannot be put on, loosen the screws of this element pre-mounted on the corners. / Ⓤ Si le panneau latéral ne peut être posé, desserrez les vis de cet élément pré-monté au niveau des coins. / Ⓦ Se non si riesce a inserire il pannello laterale, allentare le viti premontate ai lati di questo elemento. / Ⓧ Wanneer de zijwand zich er niet op laat zetten, draait u dan de op de hoeken van dit onderdeel voor-gemonteerde schroeven losser. / Ⓨ Om sidopanelen inte kan fästas, lossa skruvarna på detta element förmonterade på hörnen. / Ⓩ Hvis sidepanelet ikke kan sættes på, kan komponentens for-monterede skruer løsnes ved hjørnerne. / ⓐ Si no se puede colocar bien el panel lateral, afloja los tornillos de este elemento pre-montado en las esquinas. / ⓑ Se não conseguir inserir o painel lateral, desapertar os parafusos deste elemento pré-montado nos cantos. / ⓓ Jeśli boczna ściana nie daje się złożyć, należy poluzować śruby wstępnie zamontowane w jego narożnikach. / ⓔ Pokud nelze nasadit boční panel, povolte šrouby tohoto prvku předmontované v rozích. / ⓖ Если боковую панель закрепить невозможно, ослабьте винты, предварительно закреплённые на углах.

9.

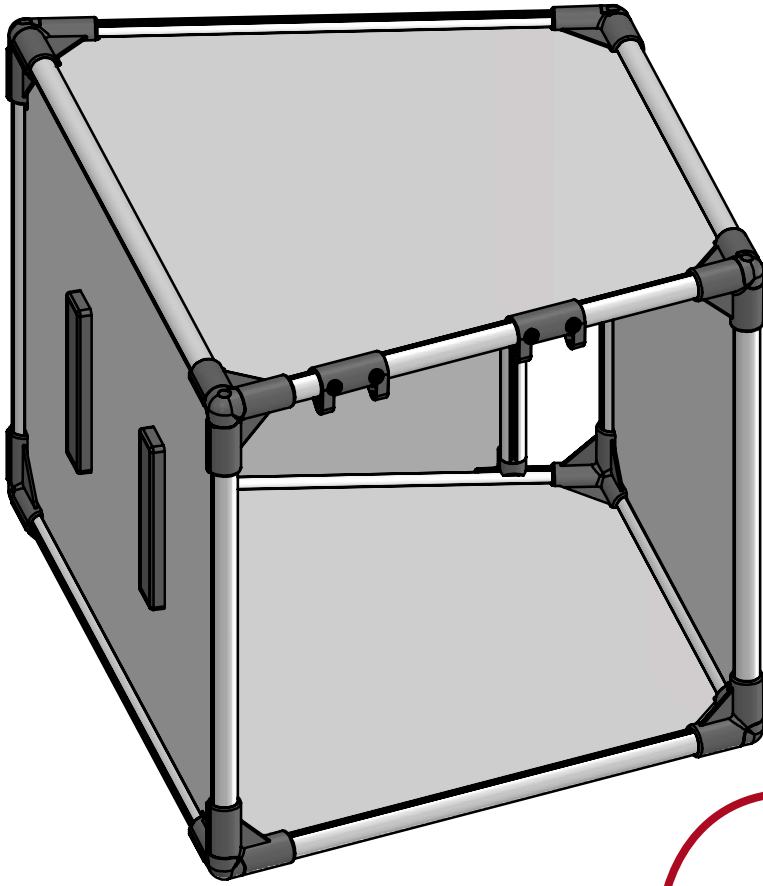

10.

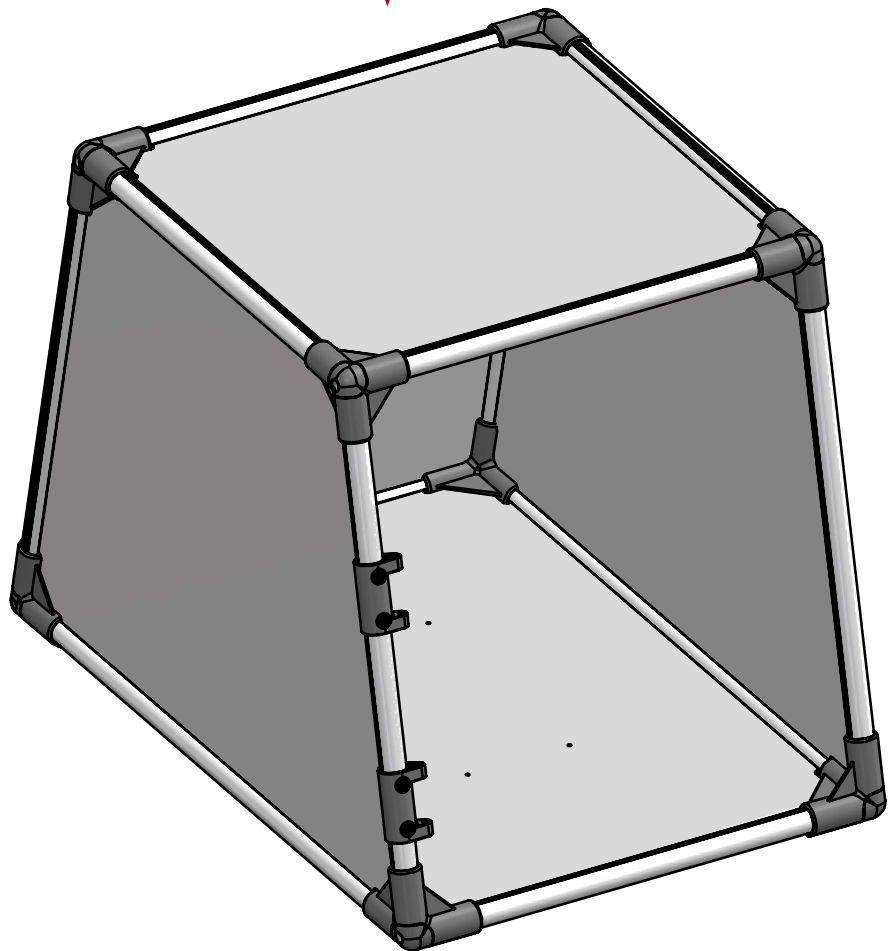

11.

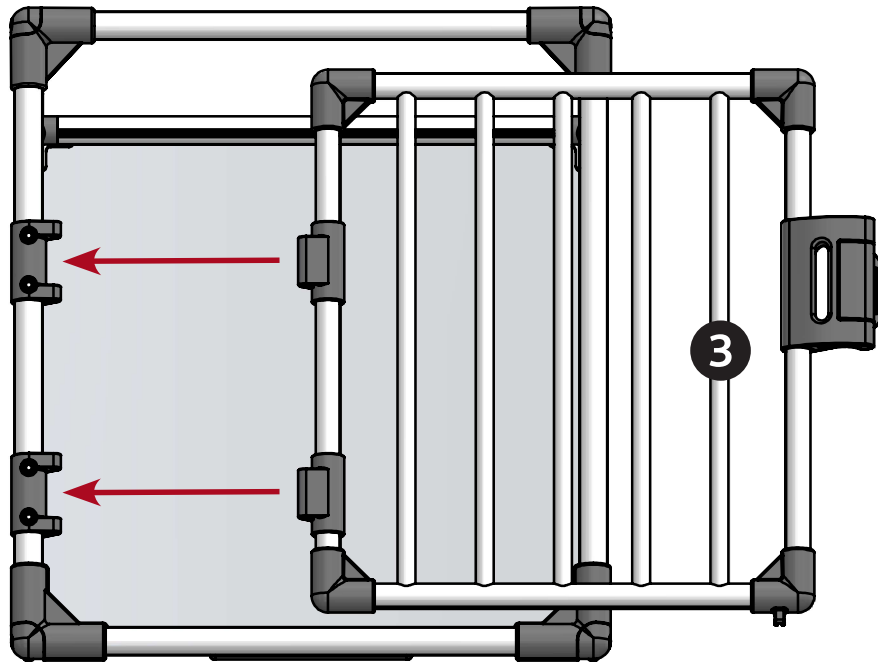

12.

